

Resa frigorifera nominale Nominal cooling capacity Puissance frigorifique nominale Nennkühlleistung Capacidad enfriamiento nominal	Efficienza Duty Efficacité Leistungsfähigkeit Rendimento	Potenza compressori Compressors power Puissance compresseurs Kompressoren Leistung Potencia compresores	Potenza pompa Pump power Puissance pompe Pumpenleistung Potencia bomba	Portata pompa Pump flow Débit pompe Pumpe Durchflußmenge Caudal bomba	Prevalenza pompa Pump pressure Pression pompe Pumpendruck Presión bomba
kW kcal/h	kW/kW	nom. max. n° kW ass. kW inst.	kW ass./inst.	l/min nom.	Bar nom.
13 11.200	5,9	1x 2,2 4,2	0,63/0,75	40	3,1

Rumorosità Noise Bruit Geräusch Ruido	Serbatoio Tank Cuve Behälter Tanque	Peso a vuoto Net weight Poids net Leergewicht Peso en vacío	Carica Gas R407C R407C Refrigerant Fill-up Charge gaz R407C Befüllung mit R407C Gas Carga gas R407C
dB(A)		litri	kg
1m	10m		
60	40	45	1,3

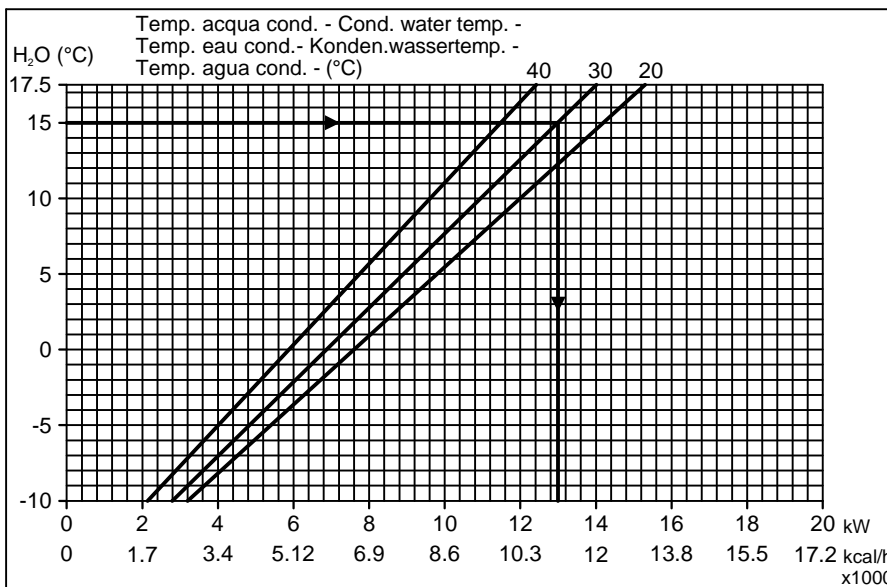
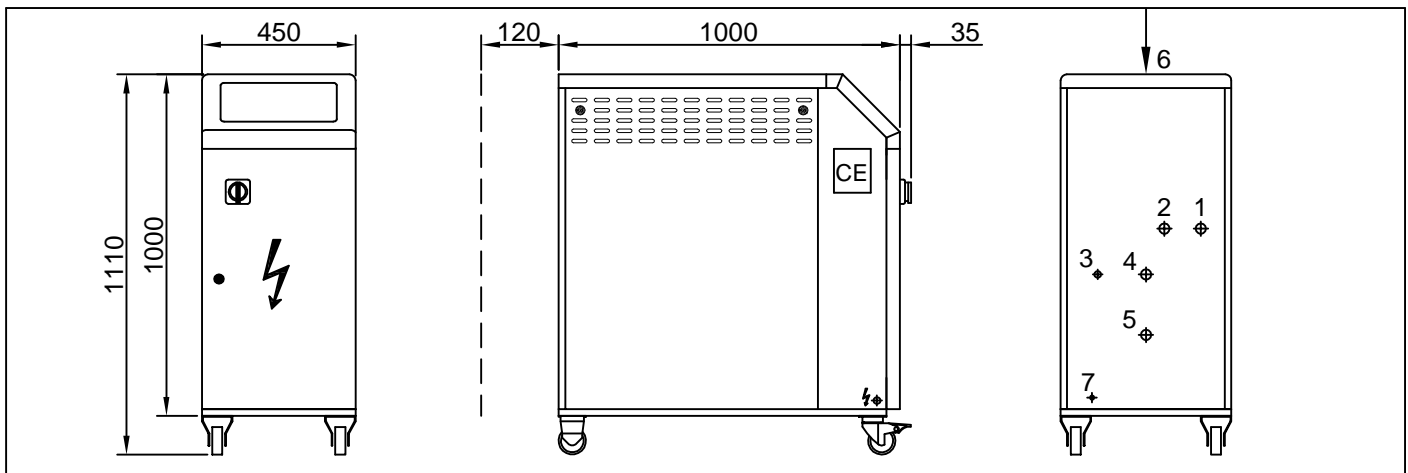

1	Mandata - Delivery - Refoulement Vorlauf - Empuje	Ø1"
2	Ritorno - Return - Retour - Rücklauf - Retorno	Ø1"
3	Riempimento - Fill up- Chargement Befüllung - Llenado	Ø1/2"
4	Entrata condensatore - Inlet conden. Entrée condenseur-Zufluss Kondens. Entrada condensador	Ø1"
5	Uscita condensatore -Outlet conden. Sortie condenseur- Ausfluss Kond. Salida condensador	Ø1"
6	Entrata glicole - Glycol inlet - Entrée glycol - Glykolzufluss - Entrada de glycol	Ø1"
7	Troppo pieno - Overflow - Trop plein - Überlauf - Rebasadero	Ø1/4"
	Scarico interno - Internal discharge - Déchargement intérieur - Innere Ablauf - Descarga interna	Ø1/2"

Tensione - Voltage Tension - Stromspannung Voltaje	Fasi - Phases Pashes - Phasen Fases	Frequenza - Frequency Fréquence - Frequenz Frecuencia	Potenza elettrica totale Total electric power Puissance électrique tot. Gesamtstromstärke Potencia eléctrica total kW ass./inst.	Corrente Max Max. Current Courant max. Max. Spannung Corriente máx. A	Magnetotermico Magnetothermic Switch Interr. Magnétothermique Magnetothermis. Schalter Interr. Magnetotérmico A
380/400/415V	3	50 Hz	3,1 / 5,0	11	16
440/460/480V		60 Hz	3,1 / 5,0	8	10
380/400V		60 Hz	3,1 / 5,0	11	16

REGLOCHILL SI RISERVA IL DIRITTO DI MODIFICARE I DATI DELLA PRESENTE SCHEDA TECNICA IN QUALUNQUE MOMENTO.
REGLOCHILL RESERVES THE RIGHT TO MODIFY THE DATA OF THIS TECHNICAL CARD IN ANY TIME, WITHOUT PRIOR NOTICE.
REGLOCHILL SE RÉSERVE LE DROIT DE MODIFIER LE DONNÉES DE CETTE FICHE TECHNIQUE SANS PRÉAVIS.
REGLOCHILL BEHÄLT SICH DAS RECHT VOR, DIE VORLIEGENDE DATEN OHNE VORHERIGE BENACHRICHTIGUNG ZU ÄNDERN
REGLOCHILL SE RESERVA EL DERECHO DE MODIFICAR LOS DATOS DE ESTA FICHA TECNICA UN QUALQUIER MOMENTO.