

Resa frigorifera nominale Nominal cooling capacity Puissance frigorifique nominale Nennkühlleistung Capacidad enfriamiento nominal	Efficienza Duty Efficacité Leistungsfähigkeit Rendimento	Potenza compressori Compressors power Puissance compresseurs Kompressoren Leistung Potencia compresores	Potenza pompa Pump power Puissance pompe Pumpenleistung Potencia bomba	Portata pompa Pump flow Débit pompe Pumpe Durchflußmenge Caudal bomba	Prevalenza pompa Pump pressure Pression pompe Pumpendruck Presión bomba
kW kcal/h	kW/kW	nom. max. n° kW ass. kW inst.	kW ass./inst.	l/min nom.	Bar nom.
10,4 8.900	5,0	1x 2,1 3,6	0,60/0,75	30	3,2

Potenza ventilatori Fans power Puissance ventilateurs Vent. Durchflußmenge Caudal ventiladores	Portata ventilatori Fan flow rate Débit ventilateur Tragfähigkeit der Ventilator Caudal ventilador	Rumorosità Noise Bruit Geräusch Ruido	Serbatoio Tank Cuve Behälter Tanque	Peso a vuoto Net weight Poids net Leergewicht Peso en vacío	Carica Gas R407C R407C Refrigerant Fill-up Charge gaz R407C Befüllung mit R407C Gas Carga gas R407C
n° kW ass./inst.	m³/h	dB(A) 1m 10m	L	kg	kg
1x 0,6/0,7	7.800	71 51	35	160	2,1

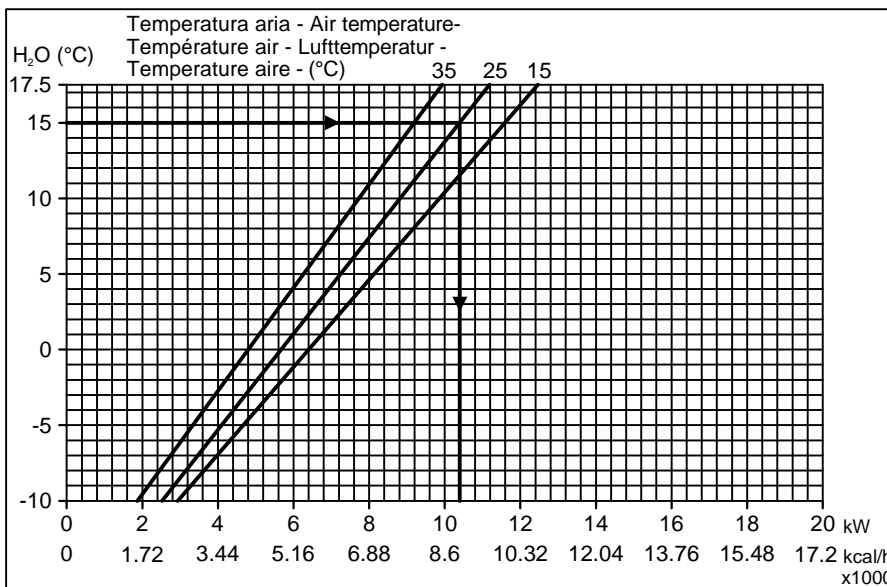
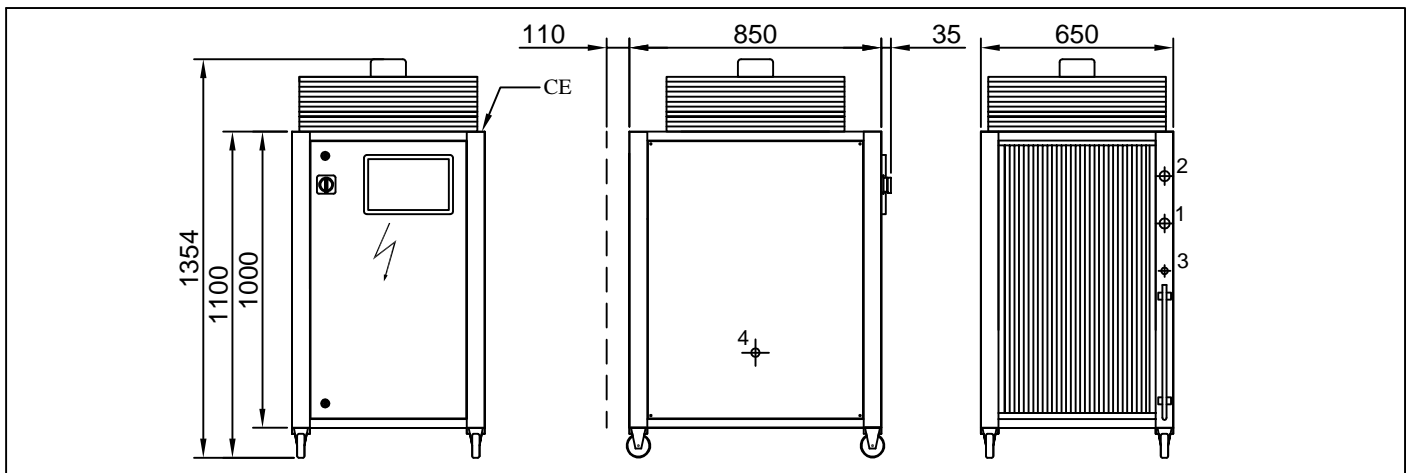

1	Mandata - Delivery - Refoulement Vorlauf - Empuje	Ø1"
2	Ritorno - Return - Retour - Rücklauf - Retorno	Ø1"
3	Riempimento - Fill up- Chargement Befüllung - Llenado	Ø1/2"
4	Entrata glicole - Glycol inlet - Entrée glycol - Glykolzufluss - Entrada de glycol	Ø3/4"
	Troppo pieno - Overflow- Trop-plein- Überlauf - Rebosadero	

Tensione - Voltage Tension - Stromspannung Voltaje	Fasi - Phases Pashes - Phasen Fases	Frequenza - Frequency Fréquence - Frequenz Frecuencia	Potenza elettrica totale Total electric power Puissance électrique tot. Gesamtstromstärke Potencia eléctrica total kW ass./inst.	Corrente Max Max. Current Courant max. Max. Spannung Corriente máx. A	Magnetotermico Magnetothermic Switch Interr. Magnétothermique Magnetothermis. Schalter Interr. Magnetotérmico A
380/400/415V	3	50 Hz	3,5 / 5,0	10	16
440/460/480V		60 Hz	3,5 / 5,0	8	10
380/400V		60 Hz	3,5 / 5,0	10	16